

## GU80N03

### N-CHANNEL ENHANCEMENT MODE POWER MOSFET

BVDSS	30V
RDS(ON)	8mΩ
ID	80A

### Description

The GU80N03 provide the designer with the best combination of fast switching, ruggedized device design, low on-resistance and cost-effectiveness.

The TO-263 package is universally preferred for all commercial-industrial surface mount applications and suited for low voltage applications such as DC/DC converters.

### Features

- \*Simple Drive Requirement
- \*Repetitive Avalanche Rated
- \*Low On-Resistance

### Package Dimensions

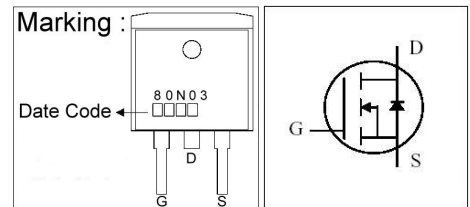
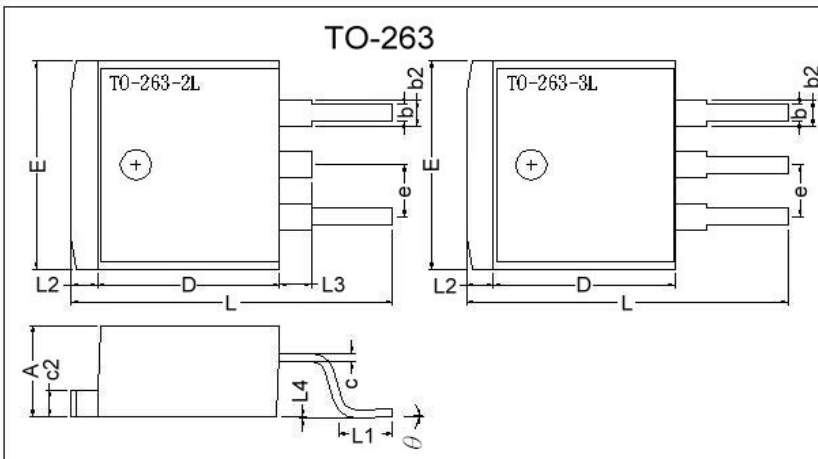

REF.	Millimeter		REF.	Millimeter	
	Min.	Max.		Min.	Max.
A	4.40	4.80	c2	1.25	1.45
b	0.76	1.00	b2	1.17	1.47
L4	0.00	0.30	D	8.6	9.0
c	0.36	0.5	e	2.54 REF.	
L3	1.50 REF.		L	14.6	15.8
L1	2.29	2.79	θ	0°	8°
E	9.80	10.4	L2	1.27 REF.	

### Absolute Maximum Ratings

Parameter	Symbol	Ratings	Unit
Drain-Source Voltage	$V_{DS}$	30	V
Gate-Source Voltage	$V_{GS}$	$\pm 20$	V
Continuous Drain Current, $V_{GS}@10V$	$I_D @T_C=25^\circ C$	80	A
Continuous Drain Current, $V_{GS}@10V$	$I_D @T_C=100^\circ C$	50	A
Pulsed Drain Current <sup>1</sup>	$I_{DM}$	315	A
Total Power Dissipation	$P_D @T_C=25^\circ C$	83.3	W
Linear Derating Factor		0.67	W/°C
Operating Junction and Storage Temperature Range	$T_j, T_{stg}$	-55 ~ +150	°C

### Thermal Data

Parameter	Symbol	Value	Unit
Thermal Resistance Junction-case	$R_{thj-c}$	1.5	°C/W
Thermal Resistance Junction-ambient	$R_{thj-a}$	62	°C/W

**Electrical Characteristics(T<sub>j</sub> = 25°C Unless otherwise specified)**

Parameter	Symbol	Min.	Typ.	Max.	Unit	Test Conditions
Drain-Source Breakdown Voltage	$BV_{DSS}$	30	-	-	V	$V_{GS}=0, I_D=250\mu A$
Breakdown Voltage Temperature Coefficient	$\Delta BV_{DSS} / \Delta T_j$	-	0.035	-	V/°C	Reference to 25°C, $I_D=1mA$
Gate Threshold Voltage	$V_{GS(th)}$	1.0	-	3.0	V	$V_{DS}=V_{GS}, I_D=250\mu A$
Forward Transconductance	$g_{fs}$	-	50	-	S	$V_{DS}=10V, I_D=40A$
Gate-Source Leakage Current	$I_{GSS}$	-	-	±100	nA	$V_{GS}= \pm 20V$
Drain-Source Leakage Current(T <sub>j</sub> =25°C)	$I_{DSS}$	-	-	1	uA	$V_{DS}=30V, V_{GS}=0$
Drain-Source Leakage Current(T <sub>j</sub> =150°C)		-	-	25	uA	$V_{DS}=24V, V_{GS}=0$
Static Drain-Source On-Resistance	$R_{DS(ON)}$	-	6	8	mΩ	$V_{GS}=10V, I_D=40A$
		-	9	12		$V_{GS}=4.5V, I_D=32A$
Total Gate Charge <sup>2</sup>	$Q_g$	-	42	-	nC	$I_D=40A$ $V_{DS}=24V$ $V_{GS}=5V$
Gate-Source Charge	$Q_{gs}$	-	5.2	-		
Gate-Drain ("Miller") Charge	$Q_{gd}$	-	26	-		
Turn-on Delay Time <sup>2</sup>	$T_{d(on)}$	-	9.9	-	ns	$V_{DS}=15V$ $I_D=40A$ $V_{GS}=10V$ $R_G=3.3\Omega$ $R_D=0.37\Omega$
Rise Time	$T_r$	-	100	-		
Turn-off Delay Time	$T_{d(off)}$	-	37	-		
Fall Time	$T_f$	-	60	-		
Input Capacitance	$C_{iss}$	-	1950	-	pF	$V_{GS}=0V$ $V_{DS}=25V$ $f=1.0MHz$
Output Capacitance	$C_{oss}$	-	895	-		
Reverse Transfer Capacitance	$C_{rss}$	-	315	-		

**Source-Drain Diode**

Parameter	Symbol	Min.	Typ.	Max.	Unit	Test Conditions
Forward On Voltage <sup>2</sup>	$V_{SD}$	-	-	1.3	V	$I_S=80A, V_{GS}=0V, T_j=25^\circ C$
Continuous Source Current (Body Diode)	$I_S$	-	-	80	A	$V_D= V_G=0V, V_S=1.3V$
Pulsed Source Current (Body Diode) <sup>1</sup>	$I_{SM}$	-	-	315	A	

Notes: 1. Pulse width limited by safe operating area.

2. Pulse width  $\leq 300\mu s$ , duty cycle  $\leq 2\%$ .

## Characteristics Curve

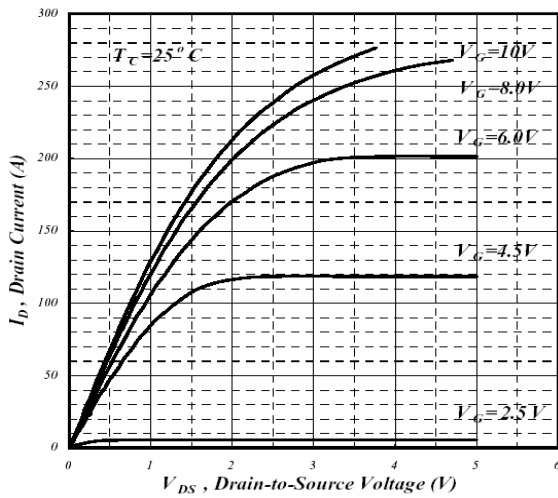

Fig 1. Typical Output Characteristics

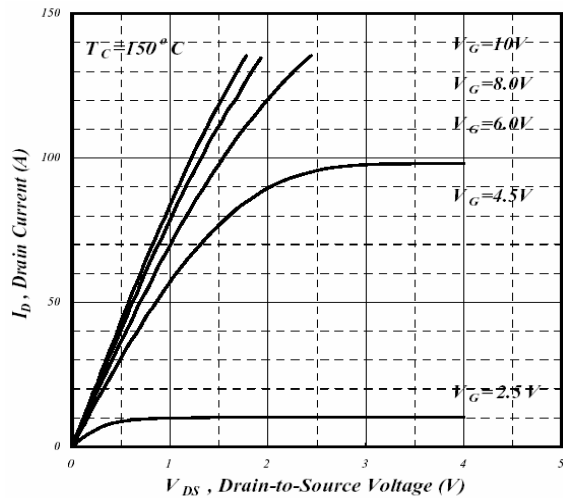

Fig 2. Typical Output Characteristics

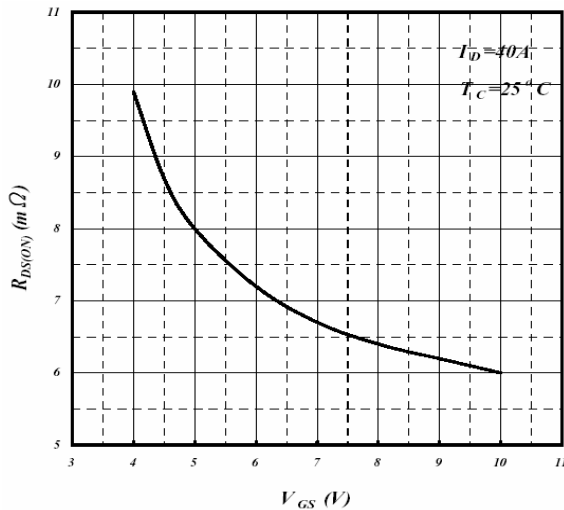

Fig 3. On-Resistance v.s. Gate Voltage

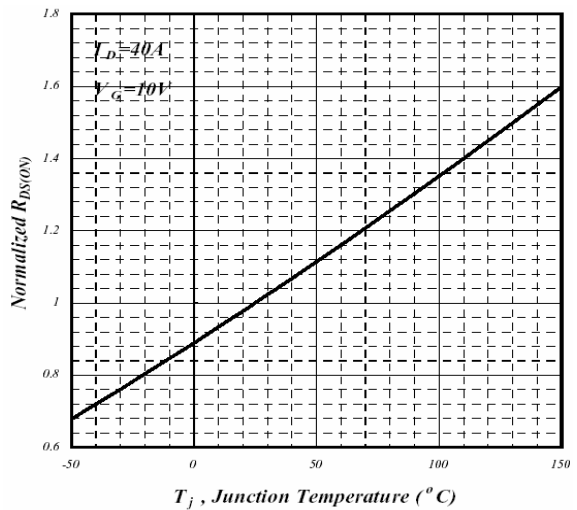

Fig 4. Normalized On-Resistance v.s. Junction Temperature

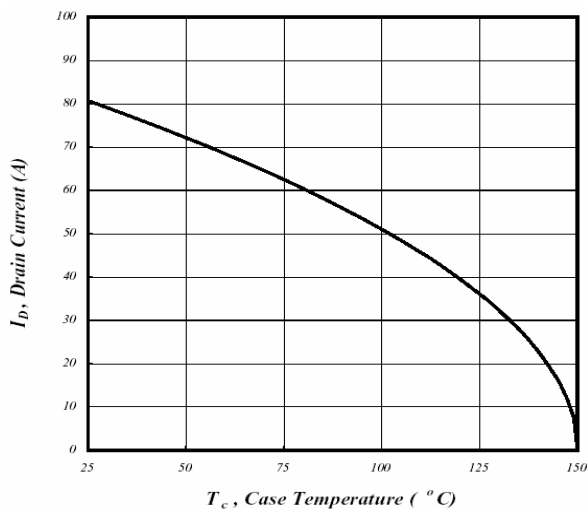

Fig 5. Maximum Drain Current v.s. Case Temperature

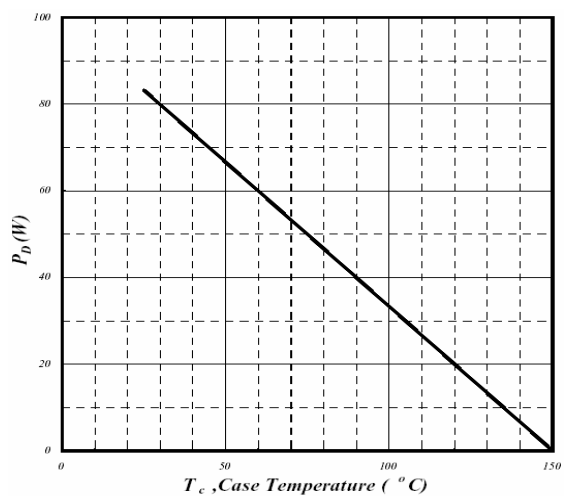
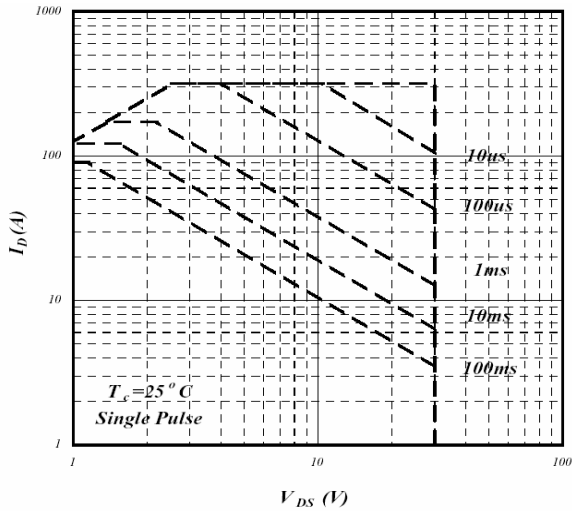
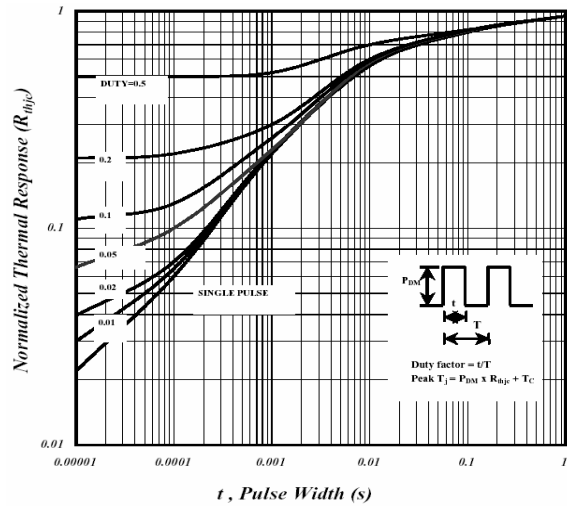

Fig 6. Type Power Dissipation



**Fig 7. Maximum Safe Operating Area**



**Fig 8. Effective Transient Thermal Impedance**

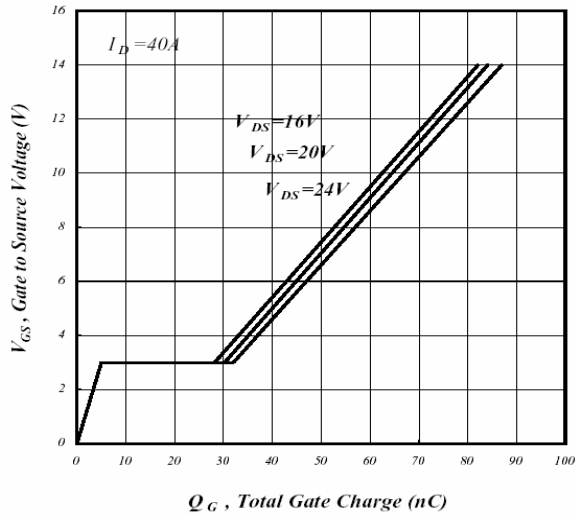

**Fig 9. Gate Charge Characteristics**

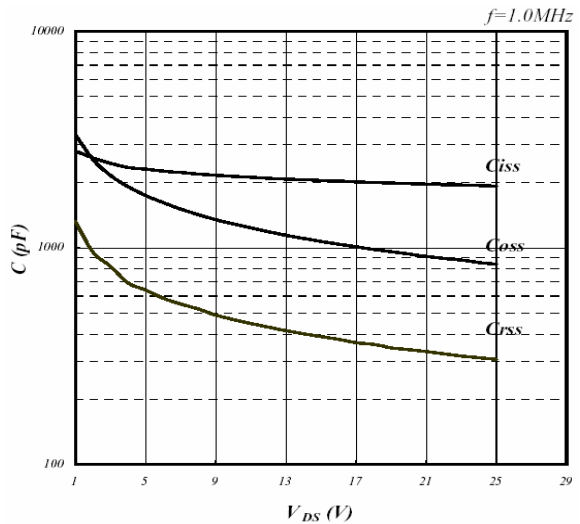

**Fig 10. Typical Capacitance Characteristics**

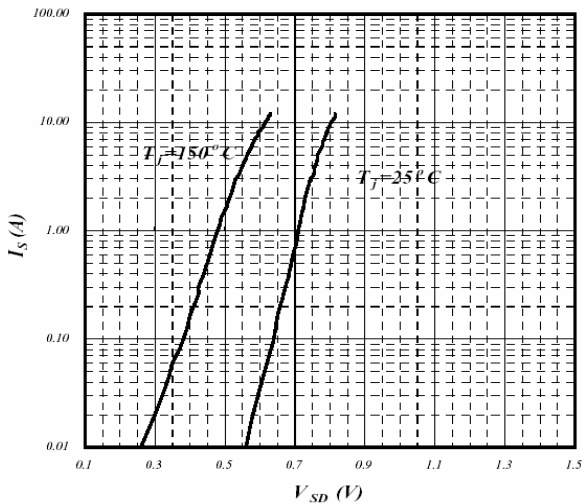

**Fig 11. Forward Characteristics of Reverse Diode**

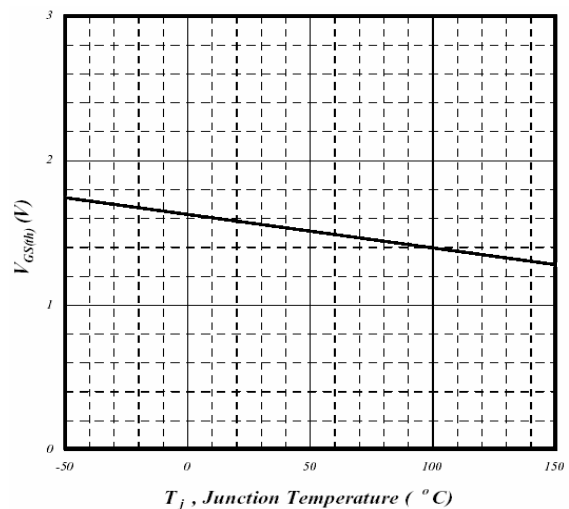

**Fig 12. Gate Threshold Voltage v.s. Junction Temperature**

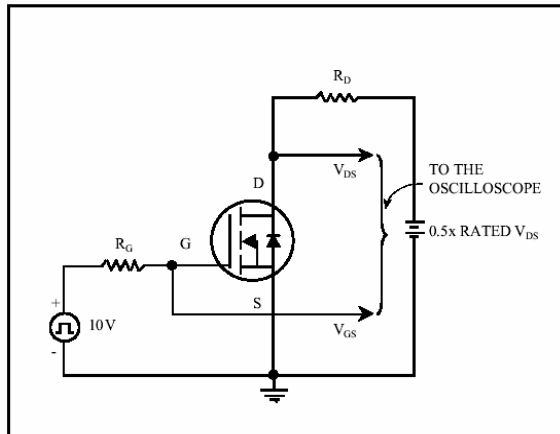

**Fig 13. Switching Time Circuit**

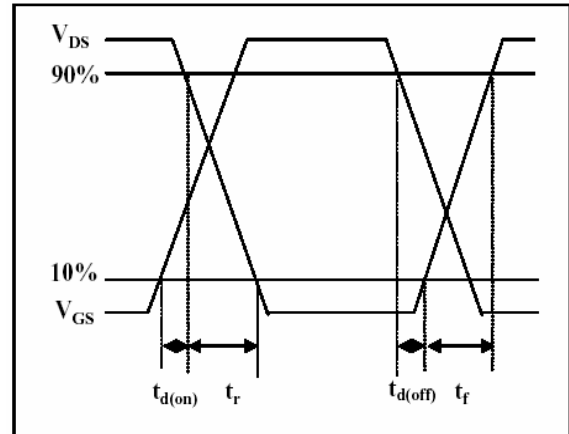

**Fig 14. Switching Time Waveform**

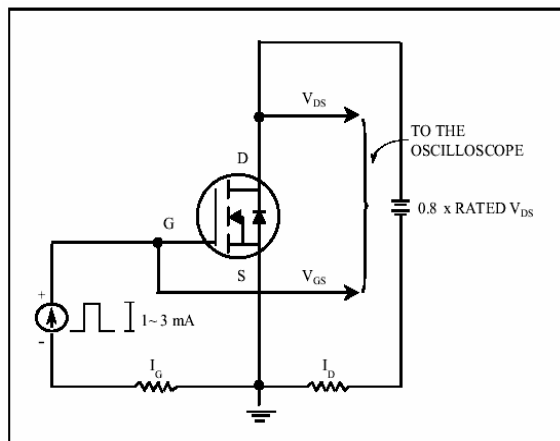

**Fig 15. Gate Charge Circuit**

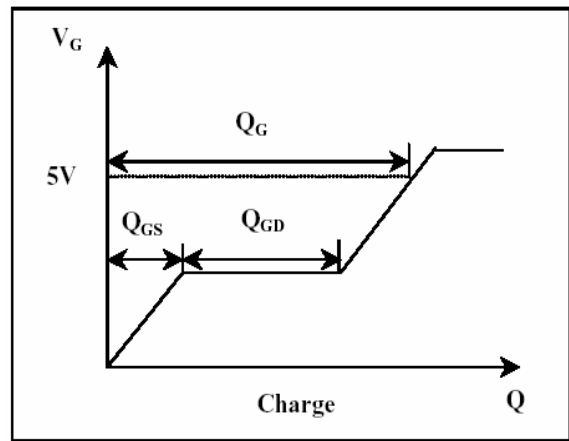

**Fig 16. Gate Charge Waveform**

**Important Notice:**

- All rights are reserved. Reproduction in whole or in part is prohibited without the prior written approval of GTM.
- GTM reserves the right to make changes to its products without notice.
- GTM semiconductor products are not warranted to be suitable for use in life-support Applications, or systems.
- GTM assumes no liability for any consequence of customer product design, infringement of patents, or application assistance.

**Head Office And Factory:**

- **Taiwan:** No. 17-1 Tatung Rd. Fu Kou Hsin-Chu Industrial Park, Hsin-Chu, Taiwan, R. O. C.
- TEL : 886-3-597-7061 FAX : 886-3-597-9220, 597-0785
- **China:** (201203) No.255, Jang-Jiang Tsai-Lueng RD. , Pu-Dung-Hsin District, Shang-Hai City, China
- TEL : 86-21-5895-7671 ~ 4 FAX : 86-21-38950165